

Danby

Silhouette

**OWNER'S MANUAL
GUIDE DU PROPRIÉTAIRE**

DBC514BLS

CAUTION:

Read and Follow All Safety Rules and Operating Instructions Before First Use of This Product.

ATTENTION :

Avant de faire fonctionner cette machine, lisez et suivez toutes les consignes de sécurité de ce guide en premier lieu.



Table of Contents	1
Table des matières	13

TABLE OF CONTENTS

Important Safety Information		3
Safety Precautions	3	
Grounding Instructions	4	
Operating Instructions		5
Features of Your Beverage Center	5	
The Controls of Your Beverage Center	6	
Setting the Temperature	6	
Wine Storage	7	
Shelf Instructions	7	
Installation Instructions		8
Tools You Will Need	8	
Preparing the Enclosure	8	
Care and Cleaning		9
Helpfull Hints	9	
How to Clean the Inside	9	
How to Clean the Outside	9	
Trouble Shooting		10
Before Your Call For Service	10	

WELCOME

Welcome to the Danby family. We're proud of our quality products and we believe in dependable service.

You'll see it in this easy-to-use manual

Best of all, you'll experience these values each time you use your Beverage Center. That's important, because your new appliance will be part of your family for a long time.

Start Here!...Before using your Beverage Center

Write down the model and serial numbers here. They are on a label located on the back of the unit

Staple your receipt to the inside back cover of this manual. You will need it to obtain service under warranty.

Model number **DBC514BLS**

Serial number _____

Date purchased _____

NEED HELP?

Before you call for service, there are a few things you can do to help us serve you better...

Read this manual

It contains instructions to help you use and maintain your appliance properly.

If you received a damaged appliance

Immediately contact the dealer (or builder) that sold you the Beverage Center.

Save time and money

Check the Trouble Shooting section before calling. This section helps you solve common problems that may occur.

IMPORTANT SAFETY INFORMATION

READ ALL SAFETY INFORMATION BEFORE USING

WARNING

DANGER, RISK OF CHILD ENTRAPMENT!

An empty refrigerator is a very dangerous attraction to children. Remove either the gasket, latches, lids, lock and/or doors from unused or discarded appliances, or take some other action to guarantee it harmless.

DON'T WAIT, DO IT NOW!

To reduce the risk of fire, burns, electric shock, or injury to persons when using your appliance, follow basic precautions, including the following sections;

SAFETY PRECAUTIONS

- This appliance must be grounded. Connect only to a properly grounded outlet. See "Grounding Instructions" section on page 4.
- Do not operate this appliance if it has a damaged power cord or plug, if it is not working properly, or if the appliance has been damaged or dropped.
- Do not splice the power cord that is equipped with this appliance.
- Keep power cord away from heated surfaces.
- Do not immerse power cord, plug or the appliance itself in water.
- Do not use this product near water-for example, in a wet basement, near a swimming pool or near a sink.
- Do not use corrosive chemicals or vapors in this appliance.
- Use this appliance only for it's intended use, as described in this manual.
- Do not store perishable food items such as (but not limited to) meats and dairy products in your Beverage Center.
- Store beverages in sealed containers only.
- See door surface cleaning instructions in the Care and Cleaning section(s) of this manual.
- Do not cover or block any openings on the appliance.
- This appliance is intended for household use only. Do not attempt to operate or store this appliance outdoors.
- This appliance should be serviced only by qualified service personnel. Contact nearest authorized service facility for examination, repair or adjustment.

SAVE THESE INSTRUCTIONS

IMPORTANT SAFETY INFORMATION

GROUNDING INSTRUCTIONS

WARNING

Improper use of the grounding plug can result in a risk of electric shock.

This appliance must be grounded. In the event of an electrical short circuit, grounding reduces the risk of electric shock by providing an escape wire for the electric current.

This appliance is equipped with a power cord having a grounding wire with a grounding plug. The plug must be plugged into an outlet that is properly installed and grounded.

Consult a qualified electrician or service technician if the grounding instructions are not completely understood, or if doubt exists as to whether the appliance is properly grounded.

If the outlet is a standard 2-prong wall outlet, it is your personal responsibility and obligation to have it replaced with a properly grounded 3-prong wall outlet.

For best operation, plug this appliance into its own electrical outlet to prevent flickering of lights, blowing of fuse or tripping of circuit breaker.

Do not under any circumstances cut or remove the third (ground) prong from the power cord.

Do not use an adapter plug with this appliance.

Do not use an extension cord with this appliance. If the power cord is too short, have a qualified electrician or service technician install an outlet near the appliance.

Operating Instructions

Features of your Beverage Centre

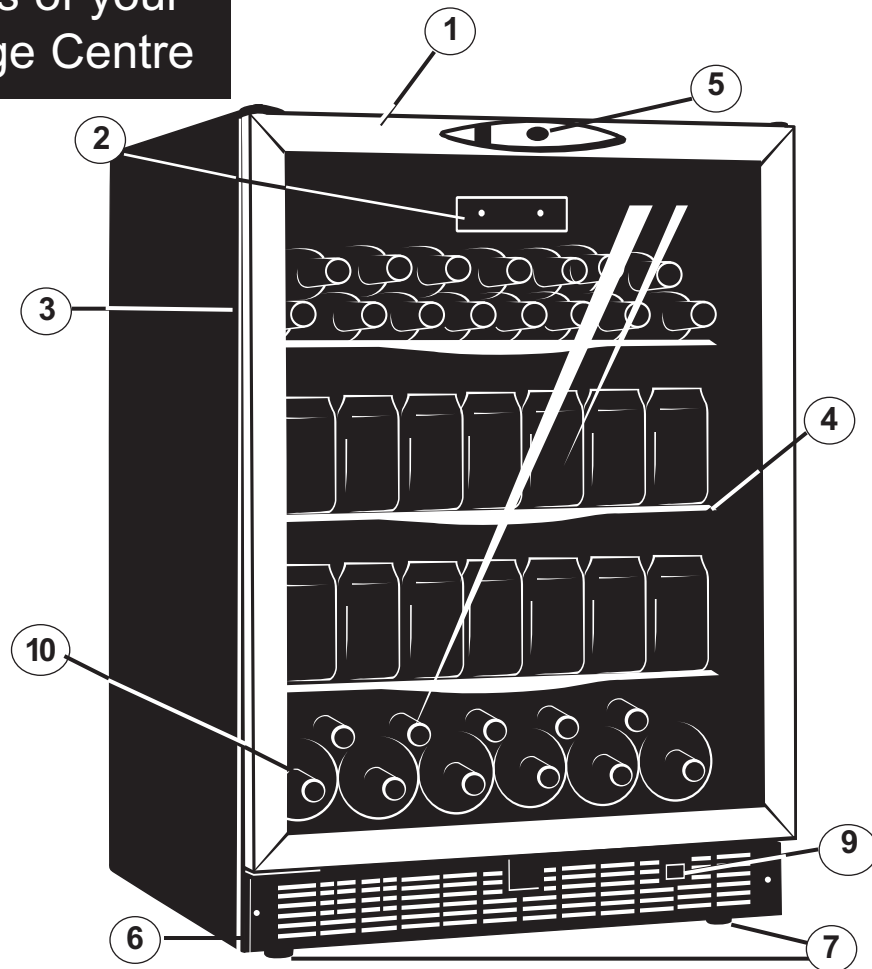

1. Tempered Glass Door: Tinted for UV protection while still allowing for easy interior viewing.

2. Electronic Display and Controls: For viewing and regulating the temperature of the Beverage Center.

3. Magnetic Door Gaskets: Tight fitting seals retain all the cooling power and humidity levels.

4. Stainless Steel Trim Shelves

5. Child Proof Lock with Key

6. Front Mounted Exhaust: Allows for integrated (built-in) applications.

7. Leveling Legs

8. Interior Light (not shown): Illuminates the compartment when the door is opened.

9. Interior Light Toggle Switch: To manually illuminate/extinguish the interior lights, while door remains closed.

10. Wine Rack: Allows for storage of up to eleven (11) bottles of wine.

Operating Instructions

The Controls of your Beverage Center

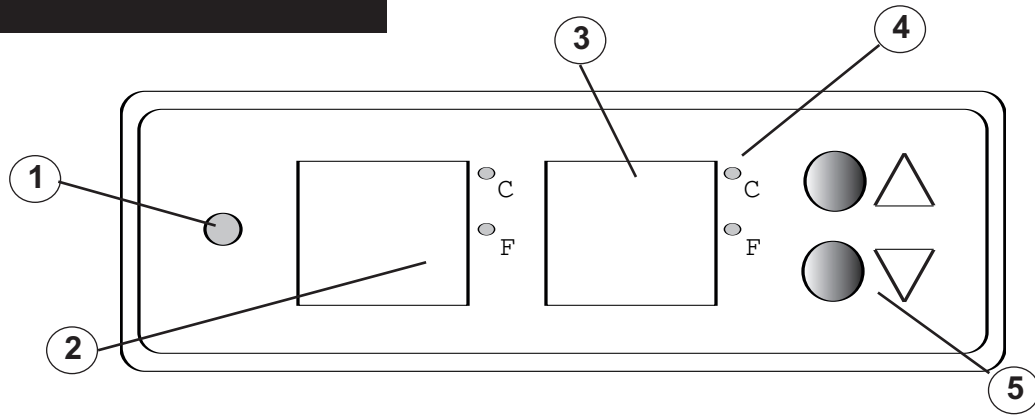

1. Run

Indicator light illuminates to signify the cooling mode is currently in operation.

2. Set Temperature Display

Display screen shows the temperature *setting* (see 'Setting the Temperature' below)

3. Cabinet Temperature Display

Display screen shows the *current* cabinet temperature.

3. C° / F°

Adjacent indicator light denotes which scale of temperature is displayed.

4. 'UP' Button

Used to raise (warmer) the temperature in 1° degree increments.

'DOWN' Button

Used to decrease (cooler) the temperature in 1° degree increments.

Setting the Temperature

When you plug in your beverage center for the first time, the temperatures will automatically be set to 45°F (7°C) and 54°F (12°C) and will be displayed in the Fahrenheit scale (°F).

- To switch the display between the Fahrenheit (°F) and Celsius (°C) scale, depress the UP and DOWN control buttons simultaneously for approximately five (5) seconds

- The temperature range can be set as low as 39°F (4°C) or as high as 64°F (18°C) to suit your specific storage requirements. Each depression of the UP or DOWN button will allow you adjust the temperature in 1° degree increments within the aforementioned range.

Please note: In the event of a power failure or interruption, all modified settings are lost and the default settings are used once power resumes.

Operating Instructions

Wine Storage

The **maximum* capacity of the wine storage rack is 11 (750ml) wine bottles.

**When stocked as per instructions.*

In order to achieve the maximum storage capacity of eleven (11) wine bottles, it may be necessary to position the glass shelves higher (see Shelf Instructions below). This will allow for the storage of six (6) 750 ml bottles in the storage “cylinders”, and five (5) bottles on the top of the rack - one (1) positioned in between each “cylinder”.

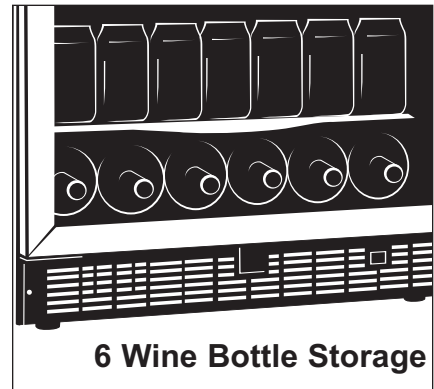

6 Wine Bottle Storage

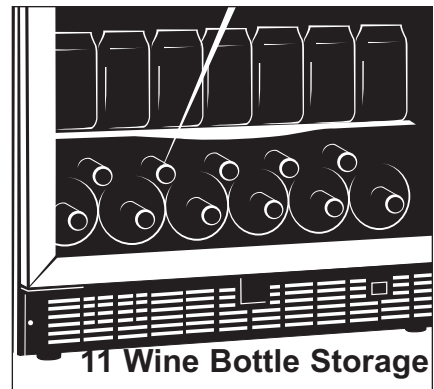

11 Wine Bottle Storage

Shelf Instructions

IMPORTANT!

Do not cover any part of the glass shelves with aluminum foil or any other material that will prevent adequate air circulation within the cabinet.

To remove a shelf from its locked position, remove the shelf stoppers located on either side of the shelf as shown in Fig C, and pull outward.

To re-install, ensure the shelf is resting securely on the support brackets and push shelf inward until it locks into place.

Please Note: The bottom wine rack is not secured in place (locked). Do not attempt to pull on the rack when it is stocked.

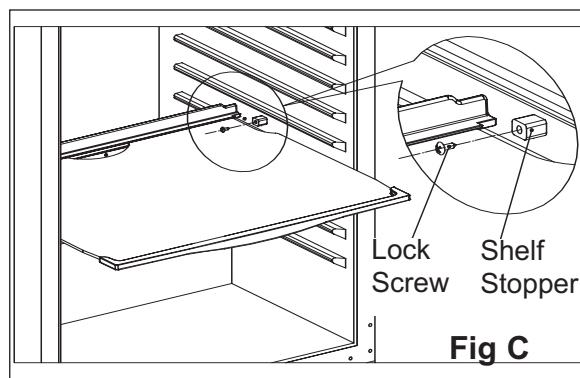

Fig C

Installation Instructions - Intergrated Application

Tools You Will Need

FOR YOUR SAFETY:

While performing installations described in this section, gloves, safety glasses or goggles should be worn.

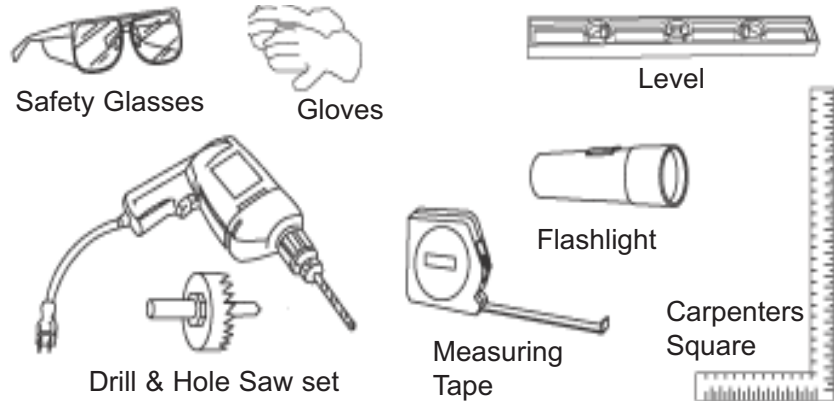

Preparing the Enclosure

Electrical Requirements:

The appliance must be connected to an individual properly grounded electrical outlet, protected by a 15 or 20 ampere circuit breaker or time delay fuse.

- It is recommended that you do not install the beverage center into a corner (i.e. directly beside a wall). This is to allow the door(s) to have a greater than 90° opening swing. A limited door swing will prevent the shelves from sliding out as intended, and may lead to damaging the door gasket(s).
- The rough cabinet opening must be on a level floor area and at least 25" deep by 24" wide. The opening should also have a height of at least 35".
- The electrical outlet may be positioned from within either side of the adjacent cabinetry, or the rear of the shaded area (as shown in Fig C.).
- If the electrical outlet is located inside the adjacent cabinetry, cut a 1-1/2" diameter hole to admit the power cord. If the cabinet wall is metal, the hole edge must be covered with a bushing or grommet.

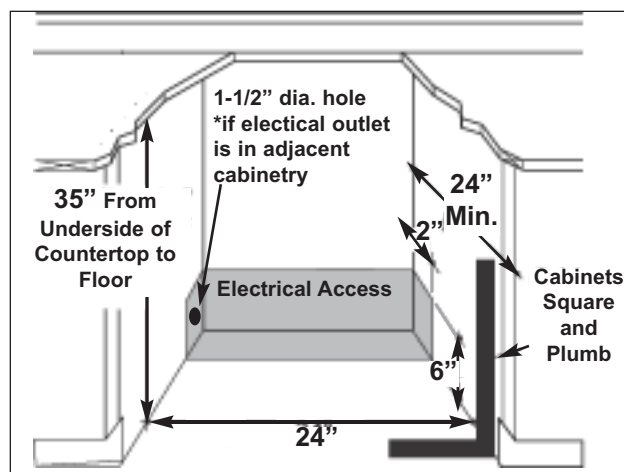

Fig C

Care and Cleaning

Helpful Hints

Allow the beverage center door to remain open for a few minutes after manual cleaning to air out and dry the inside of the wine cooler cabinet

NOTE: Be certain the power is off before cleaning any part of this appliance.

How to Clean the Inside

Walls, Floor, Inside Window, and Shelves

Never use any commercial or abrasive cleaners or sharp objects on any part of the beverage center.

Some water deposits and dust can be removed with a dry paper towel, others may require a damp cloth.

How to Clean the Outside

Do not use cleaners containing ammonia or alcohol on the beverage center.

Ammonia or alcohol can damage the appearance of the appliance.

Outer Case

It's important to keep the area clean where the door seals against the cabinet. Clean this area with a sudsy cloth. Rinse and then dry.

Door surface

Use only mild, non-abrasive detergents applied with a clean sponge or soft cloth. Rinse well.

Control Panel and Door

Wipe with a damp cloth and dry thoroughly. Do not use cleaning sprays, large amounts of soap and water, abrasive or sharp objects on the panel—they can damage it. Some paper towels may also scratch the control panel and door glass.

Trouble Shooting

Before You Call For Service

Problem	Possible Cause	What to do
No Power.	A fuse in your home may be blown or the circuit breaker tripped.	Replace fuse or reset circuit breaker.
	Power surge.	Unplug the beverage center, wait a few seconds and then plug it back in.
	Plug not fully inserted into wall outlet	Make sure the 3-prong plug is fully inserted into outlet.
Cabinet Temperature too High	Temperature setting	Verify the temperature control setting. adjust if necessary
	Door not shut properly or opened excessively	Ensure that the door is fully closed and that the gasket is sealing. against the cabinets. Open the doors only as needed and for short periods of time
	Interior lights toggled on	The interior lights are intended for temporary lighting of cabinets for display purposes only. They are not intended to be left on for prolonged time periods
	Exhaust vent is obstructed	Verify there is nothing blocking the front mounted exhausting vent.
	Recently added a large quantity of warm beverages to the cabinet	Limit the quantity of warm beverages being introduced to the cabinet at the same time. Attempt to stagger the load introduction if possible.
Condensation on the cabinet and/or doors	High humidity conditions in the home.	The condensation will subside once humidity conditions return to normal.
	Door not shut properly or opened excessively	Ensure that the door is fully closed and that the gasket is sealing. against the cabinets. Open the door only as needed and for short periods of time

Danby

Silhouette LIMITED PRODUCT WARRANTY

This quality product is warranted to be free from manufacturer's defects in material and workmanship, provided that the unit is used under the normal operating conditions intended by the manufacturer.

This warranty is available only to the person to whom the unit was originally sold by Danby or by an authorized distributor of Danby, and is non-transferable.

TERMS OF WARRANTY

Plastic parts are warranted for thirty (30) days only from purchase date, with no extensions provided.

First Two Years During the first two years (2), any electrical parts of this product found to be defective, including any sealed system units, will be repaired or replaced, at warrantor's option, at no charge to the ORIGINAL purchaser. Consumable parts (ie. light bulbs) are not warranted or guaranteed for any length of time.

Third Through Fifth Year During the next three years (3) any part of the sealed system found to be defective (consisting of compressor, condenser, evaporator, dryer and all related tubing) will be replaced without charge. The purchaser shall pay for all labour and return freight during this three period for repair or replacement of any sealed system components. Any unit being diagnosed as non-functional due to sealed system failure and warranting an exchange will be subject to an appropriate depreciation or user fee, including any and all freight charges being levied against the consumer.

To obtain Service Contact your dealer from whom your unit was purchased, or contact your nearest authorized Danby service depot, where service must be performed by a qualified service technician. If service is performed on the units by anyone other than an authorized service depot, or the unit is used for commercial application, all obligations of Danby under this warranty shall be at an end.

Nothing within this warranty shall imply that Danby will be responsible or liable for any spoilage or damage to food or other contents of this appliance, whether due to any defect of the appliance, or its use, whether proper or improper.

EXCLUSIONS

Save as herein provided, Danby Products Limited (Canada) or Danby Products Inc. (U.S.A.), there are no other warranties, conditions, representations or guarantees, express or implied, made or intended by Danby Products Limited or its authorized distributors and all other warranties, conditions, representations or guarantees, including any warranties, conditions, representations or guarantees under any Sale of Goods Act or like legislation or statute is hereby expressly excluded. Save as herein provided, Danby Products Limited (Canada) or Danby Products Inc. (U.S.A), shall not be responsible for any damages to persons or property, including the unit itself, howsoever caused or any consequential damages arising from the malfunction of the unit and by the purchase of the unit, the purchaser does hereby agree to indemnify and save harmless Danby Products Limited from any claim for damages to persons or property caused by the unit.

GENERAL PROVISIONS

No warranty or insurance herein contained or set out shall apply when damage or repair is caused by any of the following:

- 1) Power Failure.
- 2) Damage in transit or when moving the appliance.
- 3) Improper power supply such as low voltage, defective house wiring or inadequate fuses.
- 4) Accident, alteration, abuse or misuse of the appliance such as inadequate air circulation in the room or abnormal operating conditions, (extremely high or low room temperature).
- 5) Use for commercial or industrial purposes.
- 6) Fire, water damage, theft, war, riot, hostility, acts of God such as hurricanes, floods etc.
- 7) Service calls resulting in customer education.

Proof of purchase date will be required for warranty claims; so, please retain bills of sale. In the event warranty service is required, present this document to our AUTHORIZED SERVICE DEPOT.

Warranty Service

**Canada
In Home**

**United States
In Home**

Danby

Silhouette®

Model • Modèle

DBC514BLS

Integrated Beverage Center

The model number can be found on the serial plate located on the back panel of the unit.

All repair parts available for purchase or special order when you visit your nearest service depot. To request service and/or the location of the service depot nearest you, call the TOLL FREE NUMBER.

When requesting service or ordering parts, always provide the following information:

- Product Type
- Model Number
- Part Description

Centre de Breuvages Intégré

Le numéro de modèle se trouve sur la plaque signalétique au dos de l'unité.

Vous pouvez vous procurer/commander toute pièce de rechange chez votre dépositaire le plus rapproché. Pour toute demande de service ou pour localiser le dépositaire/centre de service le plus rapproché, composez le NUMÉRO SANS FRAIS.

Pour toute demande de service ou commande de pièces, fournissez toujours l'information suivante :

- Type de produit
- Numéro de modèle
- Description de la pièce requise